



SSCNA43GS6

High Frequency High Gain NPN Power BJT

➤ Features

VCB	VCE	VEB	IC
200V	200V	5V	500mA

➤ Description

This device is designed for general-purpose high-voltage amplifiers and gas discharge display drivers. It is Ideal for medium power amplification and switching.

➤ Applications

- Amplifying signal
- Electronic switch
- Oscillating circuit
- Variable resistance

➤ Ordering Information

Device	Package	Shipping
SSCNA43GS6	SOT-23	3000/Reel

➤ Pin configuration

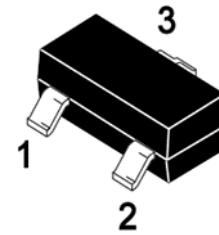

SOT-23

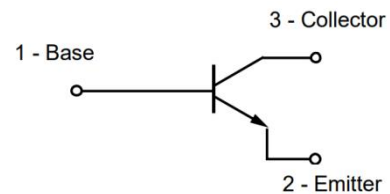

Circuit Diagram

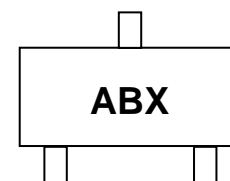

Marking (Top View)



➤ **Absolute Maximum Ratings**($T_A=25^{\circ}\text{C}$ unless otherwise noted)

Parameter	Symbol	Value	Unit
Collector-Base Voltage	V_{CB0}	200	V
Collector- Emitter Voltage	V_{CEO}	200	V
Emitter-Base Voltage	V_{EBO}	5	V
Collector Current-Continuous	I_C	500	mA
Collector Power Dissipation	P_C	350	mW
Thermal Resistance, Junction to Ambient	$R_{\theta JA}$	357	$^{\circ}\text{C}/\text{W}$
Junction Temperature	T_J	-55 to 150	$^{\circ}\text{C}$
Storage Temperature	T_{STG}	-55 to 150	$^{\circ}\text{C}$

➤ **Electrical Characteristics** ($T_A=25^{\circ}\text{C}$ unless otherwise noted)

Parameter	Symbol	Test Conditions	Min.	Typ.	Max.	Unit
Collector-Base Breakdown Voltage	BV_{CB0}	$I_C=0.1\text{mA}, I_E=0$	200			V
Collector-emitter Breakdown Voltage	BV_{CEO}	$I_C=1\text{mA}, I_B=0$	200			V
Emitter -Base Breakdown Voltage	BV_{EBO}	$I_E=0.1\text{mA}, I_C=0$	5			V
DC Current Gain	h_{FE}^*	$V_{CE}=10\text{V}, I_C=1\text{mA}$	40			
		$V_{CE}=10\text{V}, I_C=10\text{mA}$	40			
		$V_{CE}=10\text{V}, I_C=30\text{mA}$	40			
Collector-Emitter Saturation Voltage	$V_{CE(sat)}^*$	$I_C=20\text{mA}, I_B=2\text{mA}$			0.5	V
Base-Emitter Saturation Voltage	$V_{BE(sat)}^*$	$I_C=20\text{mA}, I_B=2\text{mA}$			0.9	V
Collector Output Capacitance	C_{ob}	$V_{CB}=20\text{V}, I_E=0, f=1\text{MHz}$			4	pF
Transition frequency	f_T	$V_{CE}=20\text{V}, I_C=10\text{mA}$ $f=100\text{MHz}$	50			MHz

*Pulse test: pulse width $\leq 300\mu\text{s}$, duty cycle $\leq 2.0\%$.



➤ Typical Performance Characteristics ($T_A=25^\circ\text{C}$ unless otherwise noted)

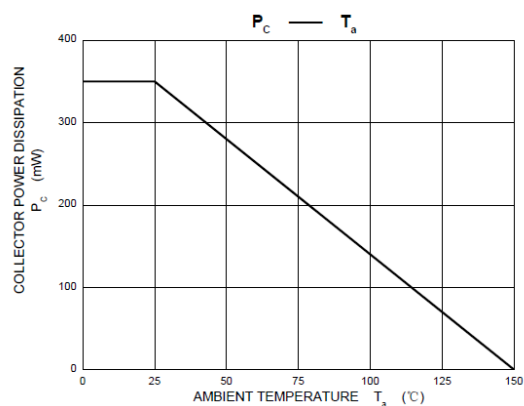
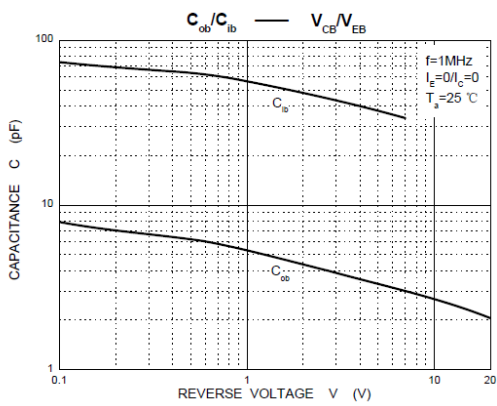
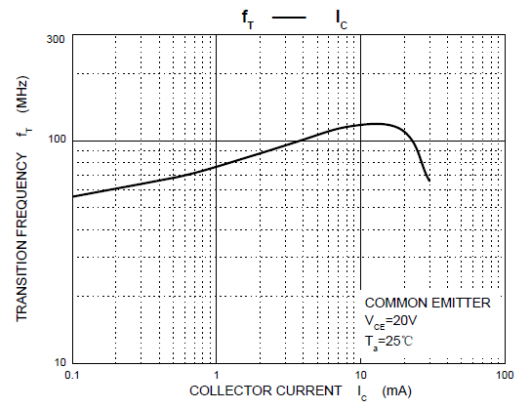
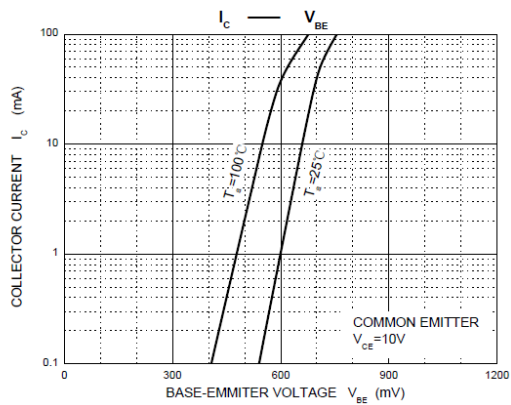
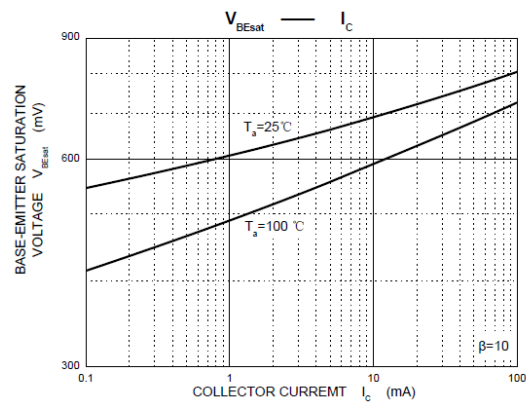
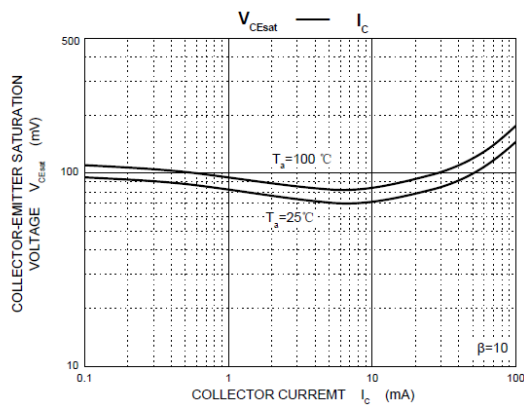
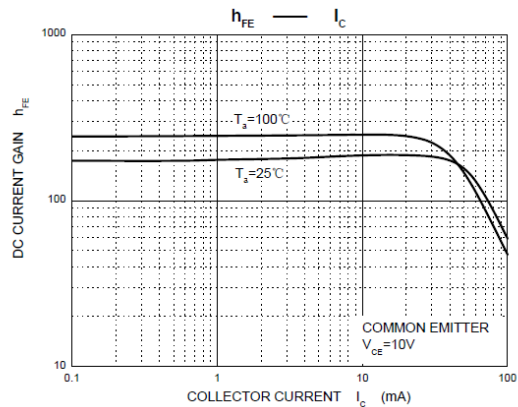
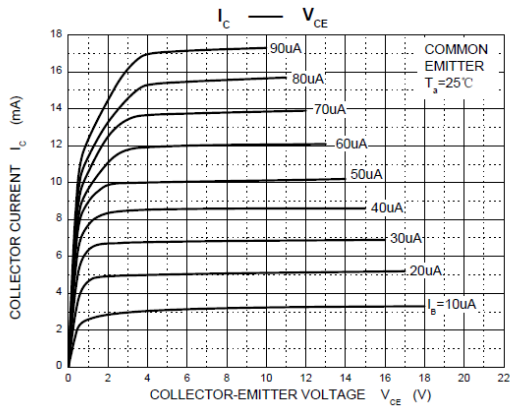



➤ **Package Information**

● **Mechanical Data**

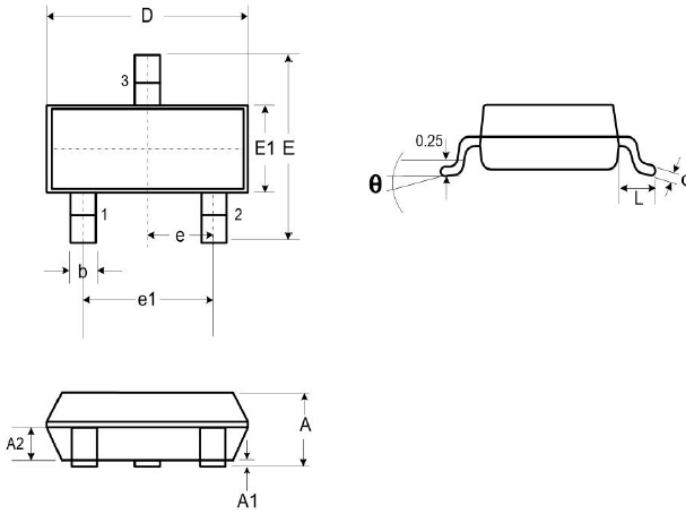

DIM	Millimeters		
	Min.	Typ.	Max.
A	0.89	-	1.12
A1	0.01	-	0.10
A2	0.88	0.95	1.02
b	0.30	-	0.51
c	0.08	-	0.18
D	2.80	2.90	3.04
E	2.10	2.37	2.64
E1	1.20	1.30	1.40
e	1.90		
e1	0.95		
L	0.40	0.50	0.60
L1	0.55		
N	3		
θ	0°	-	8°

● **Recommended Pad outline (Unit: mm)**

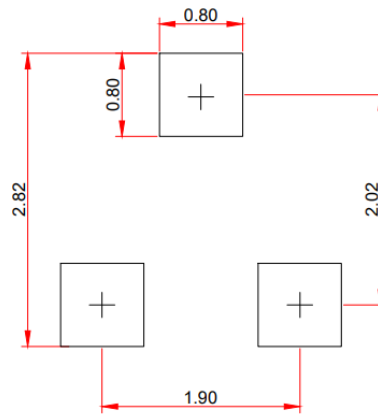



DISCLAIMER

AFSEMI RESERVES THE RIGHT TO MAKE CHANGES WITHOUT FURTHER NOTICE TO ANY PRODUCTS HEREIN TO IMPROVE RELIABILITY, FUNCTION OR DESIGN. AFSEMI DOES NOT ASSUME ANY LIABILITY ARISING OUT OF THE APPLICATION OR USE OF ANY PRODUCT OR CIRCUIT DESCRIBED HEREIN; NEITHER DOES IT CONVEY ANY LICIENCE UNDER ITS PATENT RIGHTS, NOR THE RIGHTS OF OTHERS.

THE GRAPHS PROVIDED IN THIS DOCUMENT ARE STATISTICAL SUMMARIES BASED ON A LIMITED NUMBER OF SAMPLES AND ARE PROVIDED FOR INFORMATIONAL PURPOSE ONLY. THE PERFORMANCE CHARACTERISTICS LISTED IN THEM ARE NOT TESTED OR GUARANTEED. IN SOME GRAPHS, THE DATA PRESENTED MAY BE OUTSIDE THE SPECIFIED OPERATING RANGE (E.G., OUTSIDE SPECIFIED POWER SUPPLY RANGE) AND THEREFORE OUTSIDE THE WARRANTED RANGE.